

TIN KNOCKER

TK 5' Liner Table

Instructions & Parts Diagram



TAAG INDUSTRIES CORP.

"The Tin Knocker People"

1550 Simpson Way, Escondido, CA 92029

Tel: 800-640-0746 Fax: 760-727-9948

Website: www.tinknocker.com

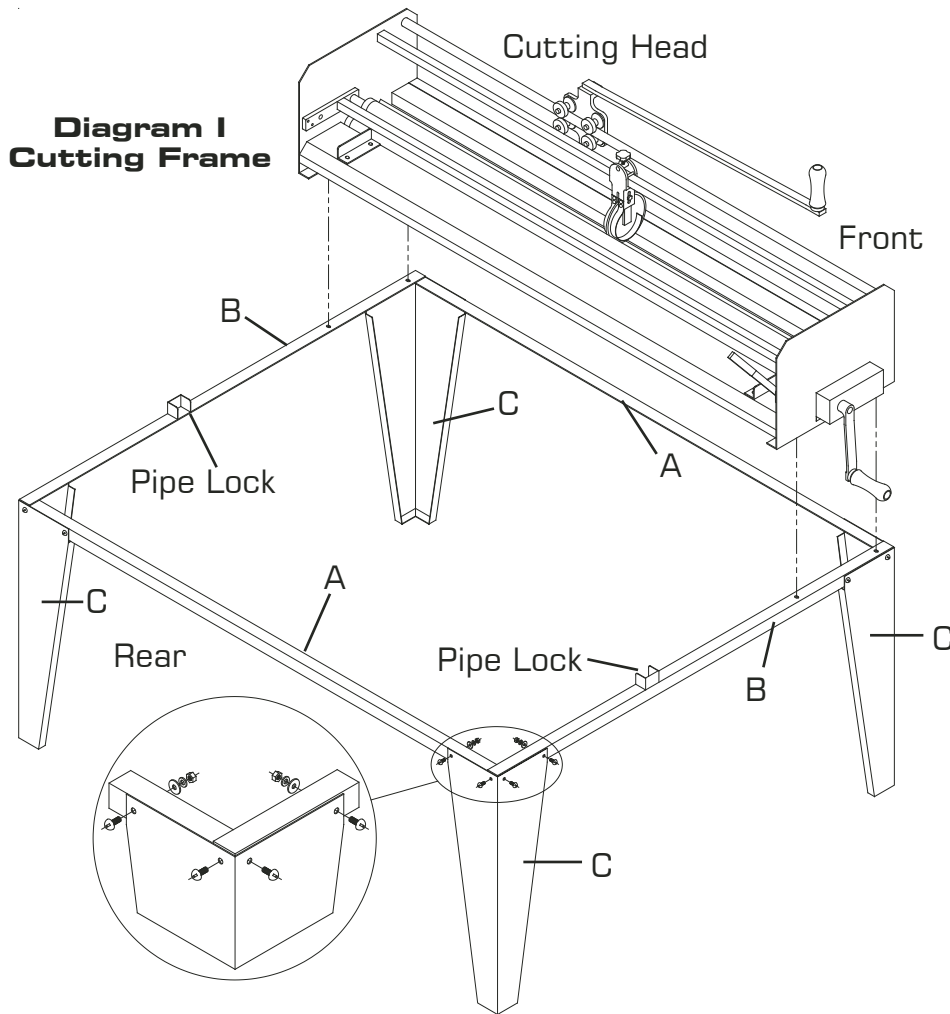
Email: info@taagind.com

ASSEMBLY INSTRUCTIONS:

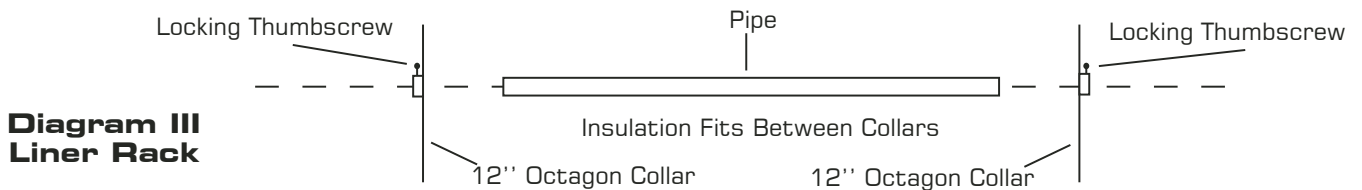
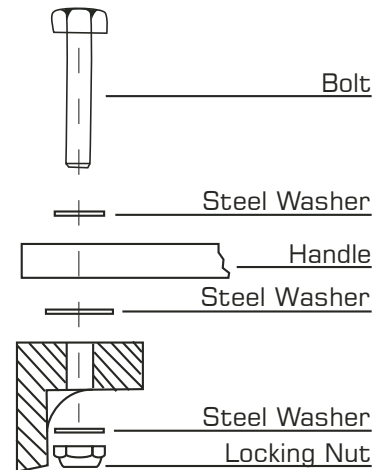
IMPORTANT: DO NOT TIGHTEN THE NUTS UNTIL THE UNIT IS COMPLETELY ASSEMBLED.

- A)** Assemble the cutting frame with the legs as shown in Diagram I. (Use 16 1/4 x 3/4 bolts with a lock washer under the nut and a flat washer under the bolt head.)
- 1)** Each frame Part "A" overlaps each frame Part "B" at the corners. (Frame parts "A" are in pairs of a right and a left.)
 - 2)** All legs "C" attach to the outside edges of the frame.
- B)** Attach the cutting head to the frame using 4 1/4 x 3/4 bolts with a lock washer under the nut and a flat washer under the bolt head.
- 1)** The Cross cut blade is toward the front of the machine.
 - 2)** Attach the handle to the cross cut assembly as shown in Diagram II.

- 3)** Insert the crank handle onto the lower drive roller shaft. Tighten the set screw.
- C)** Place one 12" octagon sheet metal collar on each piece of 1" pipe. (See Diagram III.) Put a roll of liner on the pipe. Add another sheet metal collar to the pipe.
- D)** Place the pipe in the pipelocks on the frame. (See Diagram I.)
- E)** Feed one roll of the liner into the unit.
- F)** Center the liner on the pipe so that it feeds evenly into the machine. Line up the collars with the insulation feed guides on the machine head table. Push the collars up against the roll of liner. Please allow 1/4" to 1/2" clearance between the liner and the collars. Lock the collars in place. The unit is ready for use.

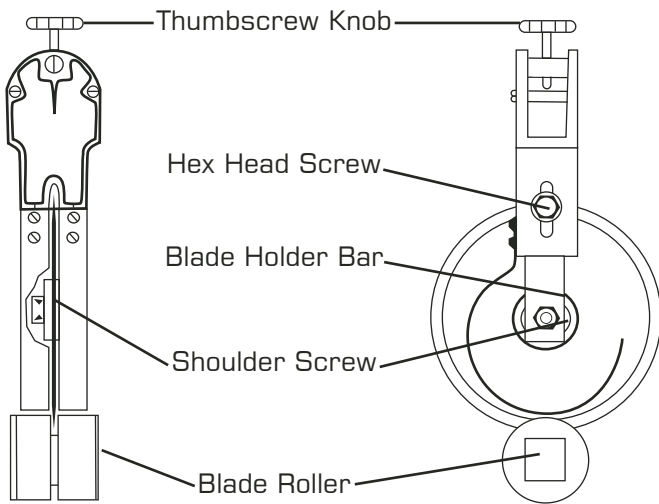


**Diagram II
Cross Cut Handle**

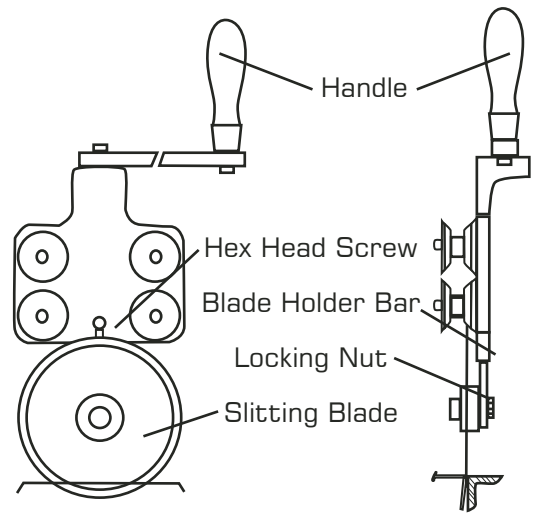


BLADE REPLACEMENT & ADJUSTMENT INSTRUCTIONS:

**Diagram IV
Sitting Assembly**



**Diagram V
Cross Cut Assembly**



IMPORTANT: THE BLADE IS VERY SHARP; USE CARE IN MAKING ADJUSTMENTS.

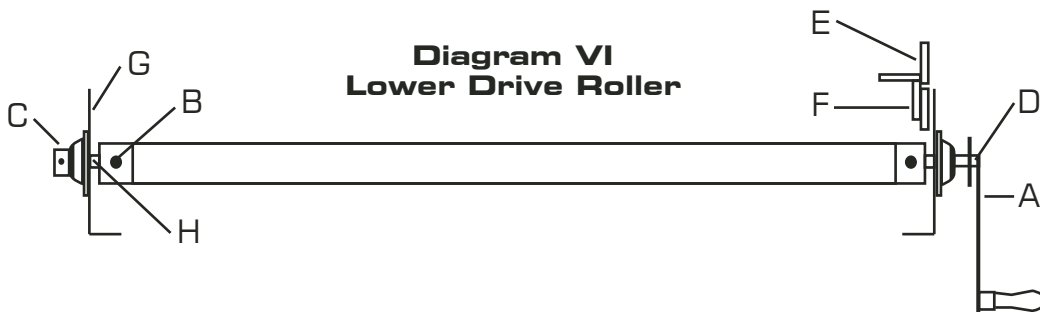
- A)** Cross Cut Trolley: Attach the blade to the holder bar using the shoulder screw and locking nut. Position the blade into the track so it protrudes into the track about 1/2". Tighten the hex head nut and screw on the cross cut trolley (Diagram V).
- B)** Slitting Blades:
 - 1)** Position the blade assembly at either end of the head. Tighten the thumbscrew knob. (Diagram IV).

- 2)** Attach the blade to the holder bar using the shoulder screw and locking nut. Position the blade in the blade roller. Insert the slitting blade about 3/32" to 1/8" into the blade roller slot. Tighten the hex head screw on the slitter blade casting.
- 3)** Check the blade assembly adjustment at the center and the opposite side of the head. The blade must rotate freely. If binding occurs at either of these positions, readjust.

NOTE: ALL THE BLADE HEIGHT ADJUSTMENTS HAVE BEEN MADE AT THE FACTORY ALL BLADES ARE INTERCHANGEABLE.

CONVERSION FOR LEFT HAND OPERATION

**Diagram VI
Lower Drive Roller**



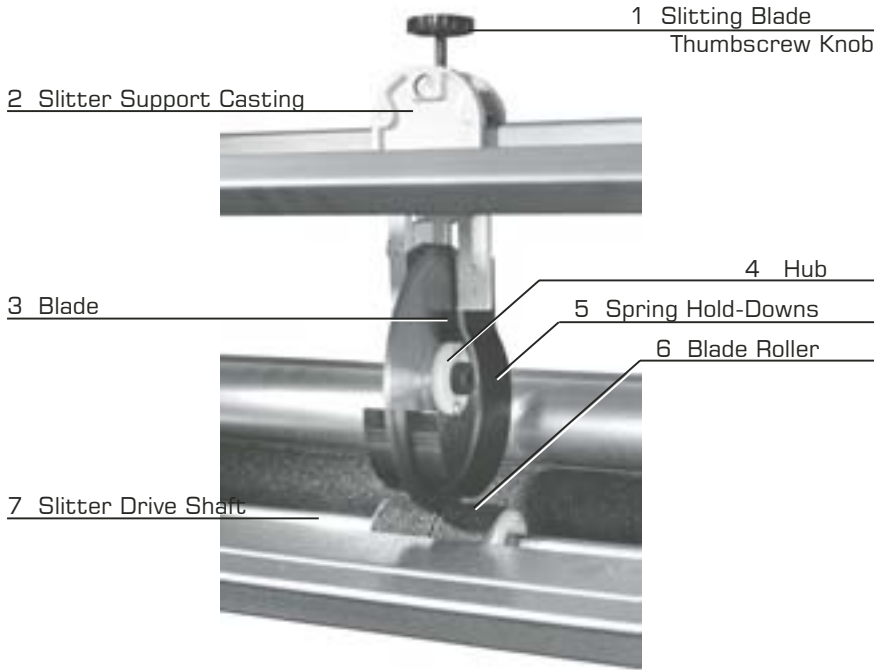
- 1)** Remove the crank handle (A).
- 2)** Loosen the set screw (B), extend the shaft (H) about 1", retighten the set screw.
- 3)** Remove the shaft collar (C), and position the crank handle (A) in place of the shaft collar. Tighten the set screw (D) in the crank handle leaving about 1/32" play. NOTE: There should be an overall lateral play in the Drive Assembly of at least 1/32".
- 4)** Place the shaft collar on opposite side of the drive roll (D) where the crank handle was positioned. The Shaft collar will secure the chain guard.

- 5)** Remove the dog stop (E). Reverse position of the pin by pressing through to the other side of the dog. Replace the dog stop on opposite side (G). The Dog must fall freely.
- 6)** Remove the upper roll lift handle (F) and replace on opposite side (G).

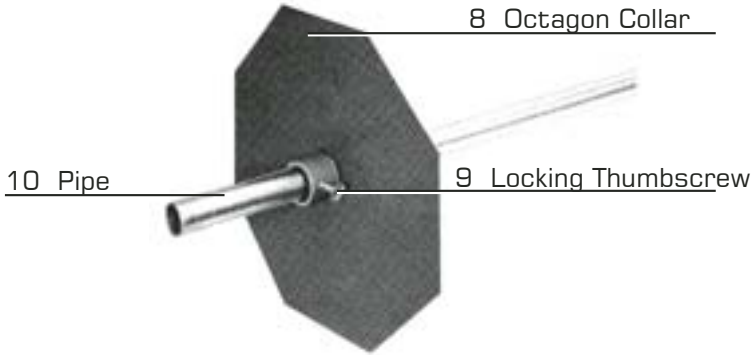
Be sure that all of the set screws are firmly tightened on flat area on shaft before operating machine.

PARTS LOCATION:

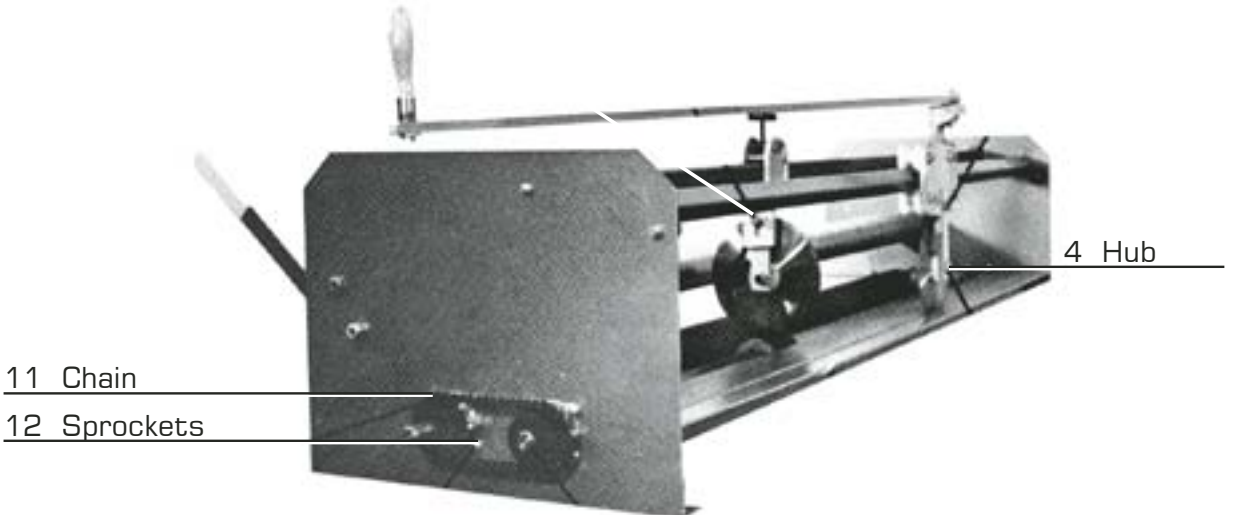
Slitting Assembly



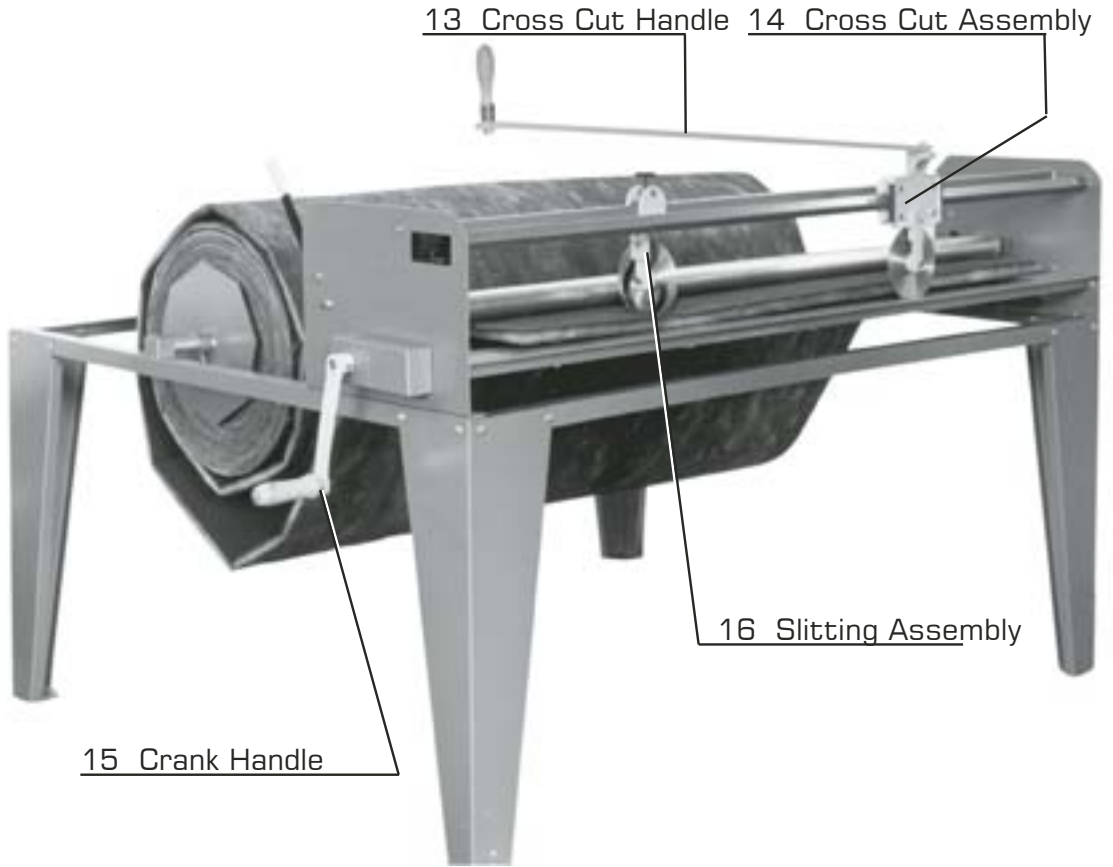
Liner Spool



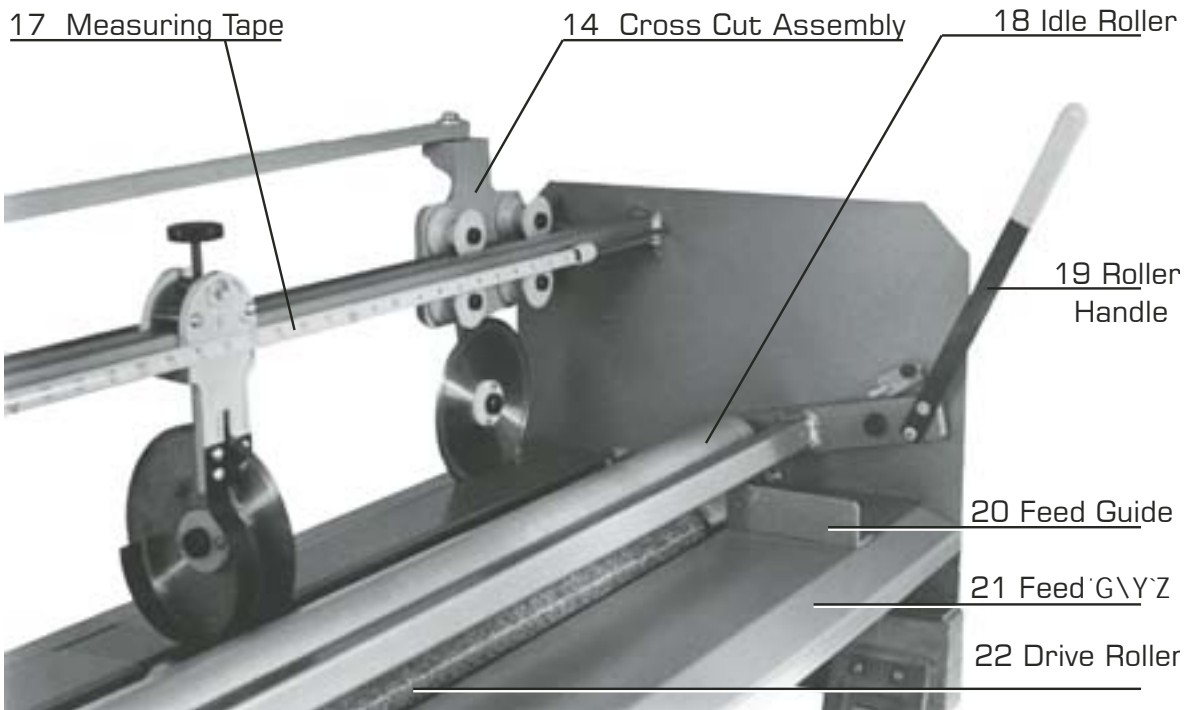
Cutting Head (Side View)



PARTS IDENTIFICATION:



**Cutting Head
(Top View)**



ADJUSTMENT & MAINTENANCE

1. Lubricate the bearing! The bearing may need to be lubricated with a light oil.
2. The cross bars that support the slitter assemblies should be lubricated as needed with a dry lubricant.
3. If any slippage occurs when feeding liner, simply push up slightly on the idler roll handle while turning the crank arm.
4. Replacement blades and parts can be ordered from TAAG Industries or a distributor.

PARTS for TK 5' LINER TABLE

Find No.	Part No.	Description	No. Req.
1	LT5001	Thumb screw knob, slitting blade	1
2	LT5002	Slitter support casting	1
3	LT5003	Blade	2
4	LT5004	Hub, blade	2
5	LT5005	Spring hold-downs	2
6	LT5006	Blade roller	1
7	LT5007	5' slitter drive shaft	1
8	LT5008	12" octagon collar	2
9	LT5009	Locking thumb screw	2
10	LT5010	Spool pipe	1
11	LT5011	Drive chain	1
12	LT5012	Drive sprockets	2
13	LT5013	Cross cut handle	1
14	LT5014	Cross cut assembly	1
15	LT5015	Crank handle	1
16	LT5016	Slitting assembly	1
17	LT5017	Measuring tape	1
18	LT5018	Idle roller	1
19	LT5019	Roller handle	1
20	LT5020	Feed guide	2
21	LT5021	Feed shelf	1
22	LT5022	Drive roller	1

TIN KNOCKER SAFETY RULES

TK 5' Liner Table

1. Never use a machine or tool for anything other than its intended purpose. Use the proper tool and equipment for the task.
2. Do not operate the machine in excess of its rated capacity.

WARRANTY

All new machines are sold with a one-year limited warranty, on factory defective parts. The warranty is limited to the original user. TAAG Machinery Co. at its option, will repair, replace or refund the purchase price of any part, tool or machine that fails during the warranty period. TAAG Machinery Co. will pay normal shipping charges for replacement parts. After 90 days from the date of purchase, all express or overnight delivery charges are the responsibility of the customer. Purchaser must deliver to TAAG Machinery Co., to the address in this manual, any written claim, with proof of original purchase. Replacement parts will be invoiced to purchaser and credit issued when the failed part is delivered to TAAG Machinery Co. Removal, re-installation or replacement parts or replacement parts shall be at purchasers/users expense. Failure due to improper use of the machine voids the warranty.

NOTE: 1. This machine has been tested and adjusted prior to shipment, but can and often does require readjustment due to vibration and bouncing during transport. Following the procedures described with can easily readjustment. These are procedures with which you, as a user, should be familiar, as you will use them repeatedly over the life use of the machine. If you have difficulty in performing these procedures, we are here to support you. Call us at: 800-640-0746. 2. Opening rolls (for Philipsburg Lock) are consumable items and not subject to warranty.